

The Novel Updates of the Hydrogeological Model of Latvia

Aivars Spalvins¹, Janis Slangens², Inta Lace³, Olgerts Aleksans⁴,
Kaspars Krauklis⁵, Viesturs Skibelis⁶, Irina Eglite⁷
¹⁻⁷Riga Technical University

Abstract – In 2010–2012, the hydrogeological model (HM) of Latvia (LAMO) was established by the scientists of Riga Technical University (RTU). LAMO is run by the commercial program Groundwater Vistas (GV). LAMO has generalized the geological and hydrogeological data that were provided for the active groundwater zone by the Latvian Environment, Geology and Meteorology Centre (LEGMC). In 2013–2014, LAMO was notably upgraded and a large amount of real hydrogeological data were added. In 2015, new improvements of LAMO were accomplished. The size of HM plane approximation step was reduced twofold (from 500 meters to 250 meters), the base flows of rivers were calibrated by using the hydrological data of measured river streams, and the permeability maps of HM aquifers were refined. The present paper describes the essence of the new updates.

Keywords – Base flow of rivers, hydrogeological model, hydrographical network, numerical interpolation, Latvia.

I. INTRODUCTION

The countries of the European Union (EU) are developing the HM which information is applied for the water resources management that must implement the EU aims defined in the Water Framework Directive [1]. In Latvia, the LEGMC specialists are preparing and updating the water resources management plans for the country.

In 2010–2012, the HM LAMO was established by the scientists of RTU. LAMO simulates the steady state mean hydrogeological situation of Latvia. In Fig. 1, the location of LAMO is shown. LAMO includes 27 geological layers (Fig. 2). The commercial program Groundwater Vistas is used for running of LAMO [2].



Fig. 1. Location of LAMO.

In [3], the methods applied to create LAMO have been explained, and they are not described in this paper.

In 2013 - 2014, LAMO was considerably updated [4], [5]. Due to these innovations, four successive versions of LAMO can be marked (Table I).

TABLE I
VERSIONS OF LAMO

Name of version	Year of disposal	Approximation grid			Rivers in the model			Lakes Number
		Plane step, meters	Number of grid planes	Number of cells, $\times 10^6$	Number	Valleys incised	Flow data used	
LAMO1	2012	500	25	14.25	199	no	no	67
LAMO2	2013	500	27	15.43	199	yes	no	67
LAMO3	2014	500	27	15.43	469	yes	no	127
LAMO4	2015	250	27	61.56	469	yes	yes	127

In 2015, the LAMO4 version was developed. In LAMO4, the following innovations were accomplished:

- the HM grid plane approximation step was decreased from 500 meters to 250 meters;
- the river base flow of HM was calibrated by using the data provided by measured river streams (see the Appendix);
- the permeability maps of LAMO4 were considerably improved [6];
- the LAMO4 version was tested as the tool for investigating the mass transport processes for a river [7].

The innovations that have turned LAMO3 into LAMO4 are explained in the paper.













II. MATHEMATICAL FORMULATIONS

To describe the new upgrades of LAMO, some mathematics of HM must be considered. By using the 3D finite-difference approximation, the $x y z$ – grid of HM is built. It consists of $(h \times h \times m)$ -sized blocks (h is the block plane step; m is the variable thickness of a geological layer). For LAMO4, $h = 250$ meters.

LAMO provides the 3D distribution of piezometric head φ as the numerical solution of the boundary field problem which is approximated in the nodes of the HM grid by the following algebraic expression [4]:

$$A\varphi = \beta - G\psi, \quad A = A_{xy} + A_z, \quad (1)$$

where A is the hydraulic conductivity matrix for the geological environment that contains horizontal (A_{xy} – transmissivity T) and vertical elements (A_z – vertical hydraulic conductivity) of the HM grid; ψ and β are the boundary head

No of HM plane		Name of layer	Geological code	HM plane code
1.		Relief	relh	relh
2.		Aeration zone	aer	aer
3.		Unconfined Quaternary	Q4-3	Q2
4.		Upper moraine	gQ3	gQ2z
5.		Confined Quaternary or Jura	Q1-3 J	Q1#
6.		Lower moraine or Triass	gQ1-3 T	gQ1#z
7.		Perma Karbons Skerveles Ketleru	P2 C1 D3šķ D3ktl	D3ktl#
8.		Ketleru	D3ktl	D3ktlz
9.		Zagares Svetes Tervetes Muru	D3žg D3sv D3tr D3mr	D3žg#
10.		Akmenes	D3ak	D3akz
11.		Akmenes Kursas Jonisku	D3ak D3krs D3jn	D3krs#
12.		Elejas Amulas	D3el D3aml	D3el#z
13.		Stipinu Katlesu Ogres Daugavas	D3stp D3ktl D3og D3dg	D3dg#
14.		Daugavas Salaspils	D3dg D3slp	D3slp#z
15.		Plavinu	D3pl	D3pl
16.		Plavinu Amatas	D3pl D3am	D3am#z
17.		Amatas	D3am	D3am
18.		Upper Gauja	D3gj2	D3gj2z
19.		Upper Gauja	D3gj2	D3gj2
20.		Lower Gauja	D3gj1	D3gj1z
21.		Lower Gauja	D3gj1	D3gj1
22.		Burtnieku	D2brt	D2brtz
23.		Burtnieku	D2brt	D2brt
24.		Arikula	D2ar	D2arz
25.		Arikula	D2ar	D2ar
26.		Narvas Narvas	D2nr2 D2nr1	D2nr#z
27.		Pernavas	D2prn	D2pr

 - aquitard

-united aquifer; #z – united aquitard

Fig. 2. Vertical schematization of LAMO.

and flow vectors, accordingly; G is the diagonal matrix assembled by the elements linking the nodes where φ must be found with the locations where ψ is given.

In GV, the flows for rivers q_{rivers} and lakes q_{lakes} are simulated, as follows:

$$q_{\text{rivers}} = G_{\text{rivers}} (\varphi - \psi_{\text{rivers}}), \quad q_{\text{lakes}} = G_{\text{lakes}} (\varphi - \psi_{\text{lakes}}), \quad (2)$$

where G_{rivers} and G_{lakes} are diagonal matrixes (part of G) that assemble the elements linking the boundary conditions ψ_{rivers} and ψ_{lakes} (part of ψ) for the rivers and lakes with nodes of HM. These links control the interaction of the HM body with the rivers and lakes. In LAMO4, the elements of G_{rivers} have been adjusted by accounting for the data provided by real measurements of the river streams (see the Appendix).

In GV, the elements a_{xy} of transmissivity T for geological layers are computed, as follows:

$$a_{xy} = k_i m_i = T_i, \quad m_i = z_{i-1} - z_i, \quad m_i = > 0, \quad i = 1, 2, \dots, p, \quad (3)$$

where z_{i-1} , z_i are elevations, accordingly, of the top and bottom surfaces of the i -th geological layer; z_0 represents the groundwater surface elevation ψ_{rel} map; p is the number of z -surfaces (for LAMO, $p = 28$); m_i and k_i are elements of the digital m_i and k_i -maps of the thickness and permeability of the i -th layer, respectively. The m -maps include the $m = 0$ areas, because most of the LAMO layers are outcropping. The presence of the $m = 0$ areas causes problems when the k -maps are created by using the formula:

$$k_i = T_i / m_i, \quad (4)$$

where the m_i -map acts as the divider; T_i is the data obtained from the pumping tests of wells. It is explained in [6] how the problem was solved when the improved k -maps for LAMO4 were created.

To accelerate the convergence of iterative solution process of the very large system (1), the ψ -type boundary conditions are fixed on the exterior surfaces (top, bottom, sides) of the HM active body. The boundary conditions ψ_{rivers} and ψ_{lakes} of (2) also increase the elements of G that ensure faster solution process of (1) [8].

III. INCREASING DENSITY OF THE LAMO GRID

The first step of changing the LAMO3 version into the LAMO4 version is increasing density for the HM grid, in order to match the HM body with the fine hydrological network of LAMO3. In LAMO3, some elements of the network were located so close that they were touching. The drawback can be eliminated if the plane approximation step of HM is reduced from 500 meters to 250 meters. Then density of the HM grid increases fourfold.

In order to investigate how the change in the grid step effects the distribution of all LAMO flows (q_{inflow} , q_{rivers} , q_{lakes} , q_{wells}), the intermediate version LAMO4.1 was created. The elements of k -maps and m -maps were obtained by linear interpolation. Elements of the ψ -type boundary conditions also

were interpolated In a figurative sense, LAMO4.1 was the “clone” of LAMO3.

In Table II, groundwater flows are given for the LAMO versions. It is obvious that the flows q_{inflow} , q_{rivers} , q_{lakes} of the LAMO4.1 version are smaller than the ones of LAMO3.

TABLE II
GROUNDWATER FLOWS, THOUS. M³/DAY, FOR LAMO VERSIONS

Name of version	q_{inflow}	q_{rivers}	q_{lakes}	$q_{boundary}$	q_{wells}
LAMO2	7199	-5680	-428	-936	-155
LAMO3	10 763	-9436	-599	-499	-155
LAMO4.1	10 349	-9104	-541	-549	-155
LAMO4.2	14 221	-12 386	-825	-855	-155

LAMO4.1 is the “clone” of LAMO3;

LAMO4.2 is calibrated by adjusting q_{rivers} .

TABLE III
FLOWS OF RIVERS AND LAKES IN LAMO3 AND LAMO4.1

Name of version	Groundwater flow, thous. m ³ /day		Number of nodes joined with rivers and lakes		Area joined with rivers and lakes, km ²	
	q_{rivers}	q_{lakes}	N_{rivers}	N_{lakes}	L_{rivers}	L_{lakes}
LAMO3	9436	599	42 137	6093	10 534	1523
LAMO4.1	9104	541	89 683	19 321	5605	1207

In Table III, information is presented about the areas which join the HM with rivers and lakes. These data explain why the flows q_{rivers} and q_{lakes} in LAMO4.1 are smaller than in LAMO3. The areas L_{river} and L_{lakes} that have links with rivers and lakes can be computed, as follows:

$$L_{river} = N_{river} h^2, \quad L_{lakes} = N_{lakes} h^2 \quad (6)$$

where N_{river} and N_{lakes} are the number of rivers and lakes, respectively. By using (6), data of Table III were obtained if $h = 0.5$ km and 0.25 km for LAMO3 and LAMO4.1, respectively. For LAMO4.1, $N_{river} = 89 683$ is almost two times larger than for LAMO3 (42 137). The area $L_{river} = 5605$ km² for LAMO4.1 is almost two times smaller than that for LAMO3 (10 534 km²). For this reason, q_{rivers} is smaller for LAMO4.1. However, the sum of links for G_{rivers} is almost equal for both versions.

For LAMO4.1, the L_{lakes} area is smaller than that for LAMO3, because the number N_{lakes} is smaller for LAMO4.1. This is caused by the finer approximation of the lake areas, when $h = 250$ meters. For this reason, q_{lakes} is smaller for LAMO4.1. The decrease in the flow q_{inflow} for LAMO4.1 is caused by the the smaller flows q_{rivers} and q_{lakes} .

IV. CALIBRATION OF HM BY ACCOUNTING FOR MEASURED RIVER STREAMS

The second step of creating of LAMO4 is the change of the LAMO4.1 version into LAMO4.2 by accounting for the data provided of measured river streams. It is explained in the Appendix how these data have been used for obtaining the targets for calibration of 69 primary drainage basins of

LAMO. The links G_{river} of (2) were adjusted to match the simulated q_{river} with the target flow of the basin under consideration. It follows from Table IA in the Appendix that the rather close match has been achieved for each primary basin and also for the whole territory of Latvia.

In Tables IV–VIII, the simulated groundwater flows for Latvia and for the united river basins of Gauja, Daugava, Lielupe, and Venta are represented, accordingly. Each row of those Tables contains the local groundwater flow balance that is obtained by the mass balance tool of GV.

For an aquifer, GV computes the flows q_{topin} , q_{topout} , q_{botin} , and q_{botout} . The sum of these flows is the inflow q_{inflow} :

$$q_{inflow} = q_{topin} + q_{topout} + q_{botin} + q_{botout} \quad (7)$$

The flow q_{inflow} exists only for the $m > 0$ area of a layer. The GV system also finds the flows q_{river} , q_{lakes} , q_{border} , and q_{wells} , accordingly, for rivers, lakes, external boundaries, and exploitation wells.

The sum of these flows must be in balance with q_{inflow} :

$$q_{inflow} + q_{river} + q_{lakes} + q_{border} + q_{wells} = 0 \quad (8)$$

The graphical scheme for the expressions (7) and (8) is given in Figs 3a and 3b, correspondingly. There the “Module” represents any part of the geological environment which flow balance is under consideration.

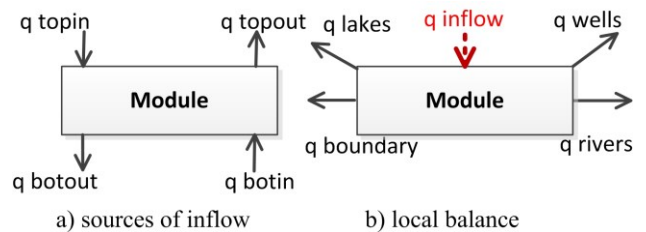

Fig. 3. The scheme for explanation of the flow balance.

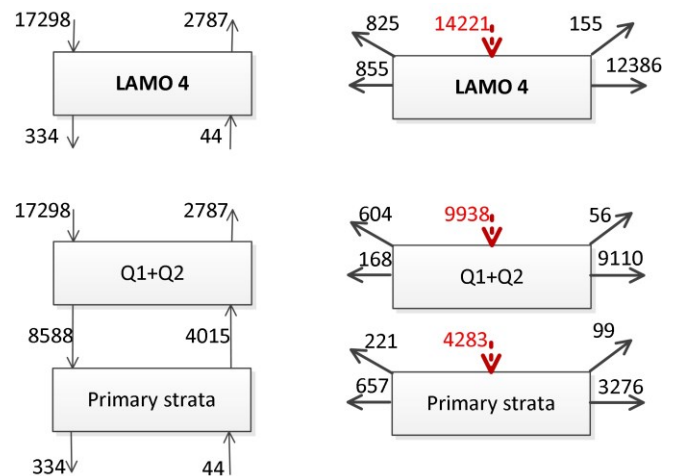

Fig. 4. Mass balances, thous. m³/day, for LAMO4, Latvia.

In Tables IV–VIII, the local flow balance is given for any aquifer, for whole HM, for the Quaternary, and for Primary strata systems.

In Fig. 4, the last three rows of Table IV are exposed.

In the Tables IV–VIII, the row for the Q2 aquifer does not provide the full information about the flow balance on the top of HM. It follows from this balance that some part of the infiltration flow q_{inf} returns for the ground surface as the runoff flow q_{runoff} . This fact is explained in Table IX, where the balance on the top of Q2 aquifer is shown for the united river basins and for Latvia. The ratio q_{runoff}/q_{inf} shows the relative part of the infiltration that turns into the surface runoff flow. It takes place at areas where the ascending groundwater flow reaches the land surface, usually, at lowland areas.

The data regarding flow balances for Latvia and its four united river basins will be analyzed in order to obtain deeper understanding of the groundwater processes of the country. The computer-based inventory for river base flows q_{river} will be developed in order to account for sources that support them.

TABLE IV
LATVIA GROUNDWATER FLOWS, THOUS. M³/DAY

Aquifer code	q_{inflow}	q_{rivers}	q_{lakes}	q_{border}	q_{wells}
Q2	9723	-8920	-603	-144	-56
Q1#	215	-190	-1	-24	0
D3ktl#	187	-199	-16	29	-1
D3zg#	68	-63	-3	2	-4
D3krs#	101	-74	0	-23	-4
D3dg#	976	-762	-176	-34	-4
D3pl	627	-463	-12	-144	-8
D3am	210	-202	0	-7	-1
D3gj2	597	-484	0	-88	-25
D3gj1	442	-282	-6	-129	-25
D2brt	916	-747	-8	-148	-13
D2ar	153	0	0	-145	-14
Model	14221	-12386	-825	-855	-155
Q1+Q2	9938	-9110	-604	-168	-56
Primary aquifers	4283	-3276	-221	-687	-99

TABLE V
THE GAUJA RIVER BASIN GROUNDWATER FLOWS, THOUS. M³/DAY

Aquifer code	q_{inflow}	q_{rivers}	q_{lakes}	q_{border}	q_{wells}
Q2	1925	-1806	-80	-31	-8
Q1#	52	-47	0	-5	0
D3dg#	136	-110	0	-26	0
D3pl	120	-104	0	-16	0
D3am	131	-131	0	0	0
D3gj2	397	-417	0	20	0
D3gj1	219	-214	-6	2	-1
D2brt	681	-642	0	-34	-5
D2ar	30	0	0	-2	-5
Model	3691	-3471	-86	-116	-18
Q1+Q2	1977	-1853	-80	-37	-7
Primary aquifers	1714	-1618	-6	-79	-11

TABLE VI
THE DAUGAVA RIVER BASIN GROUNDWATER FLOWS, THOUS. M³/DAY

Aquifer code	q_{inflow}	q_{rivers}	q_{lakes}	q_{border}	q_{wells}
Q2	4839	-4448	-368	26	-49
Q1#	83	-90	-1	8	0
D3dg#	504	-317	-172	-11	-4
D3pl	431	-302	-12	-110	-7
D3am	7	-2	0	-5	0
D3gj2	113	-12	0	-80	-21
D3gj1	108	0	0	-101	-7
D2brt	84	0	0	-82	-2
D2ar	78	0	0	-77	-1
Model	6247	-5171	-553	-432	-91
Q1+Q2	4922	-4538	-369	-34	-49
Primary aquifers	1325	-633	-184	-466	-42

TABLE VII
THE LIELUPE RIVER BASIN GROUNDWATER FLOWS, THOUS. M³/DAY

Aquifer code	q_{inflow}	q_{rivers}	q_{lakes}	q_{border}	q_{wells}
Q2	969	-947	-29	7	0
Q1#	8	-8	0	0	0
D3ktl#	0	0	0	0	0
D3zg#	13	-16	0	3	0
D3krs#	15	-17	0	3	-1
D3dg#	105	-125	-1	21	0
D3pl	8	-1	0	-7	0
D3am	-1	0	0	2	-1
D3gj2	-8	0	0	11	-3
D3gj1	-1	0	0	15	-14
D2brt	-7	0	0	8	-1
D2ar	-1	0	0	1	0
Model	1100	-1114	-30	64	-20
Q1+Q2	977	-955	-29	7	0
Primary aquifers	123	-159	-1	57	-20

TABLE VIII
THE VENTA RIVER BASIN GROUNDWATER FLOWS, THOUS. M³/DAY

Aquifer code	q_{inflow}	q_{rivers}	q_{lakes}	q_{border}	q_{wells}
Q2	1990	-1719	-126	-145	0
Q1#	72	-45	0	-27	0
D3ktl#	187	-199	-16	29	-1
D3zg#	55	-47	-3	1	-4
D3krs#	86	-57	0	-26	-3
D3dg#	231	-210	-3	-18	0
D3pl	68	-56	0	-12	0
D3am	73	-69	0	-4	0
D3gj2	95	-55	0	-39	-1
D3gj1	116	-68	0	-45	-3
D2brt	158	-105	-8	-40	-5
D2ar	52	0	0	-43	-9
Model	3183	-2630	-156	-371	-26
Q1+Q2	2062	-1764	-126	-172	0
Primary aquifers	1121	-866	-30	-199	-26

TABLE IX

THE SURFACE RUNOFF FLOW q_{runoff} , THOUS. M³/DAY, ORIGINATED FROM INFILTRATION q_{inf}

Name of basin	$q_{\text{topin}} (q_{\text{inf}})$	$q_{\text{topout}} (q_{\text{runoff}})$	$q_{\text{toprez}} (2+3)$	$q_{\text{runoff}}/q_{\text{inf}} (3/2)$
1	2	3	4	5
Gauja	4265	-529	3736	-0.124
Daugava	7726	-1251	6475	-0.162
Lielupe	1334	-246	1088	-0.184
Venta	3973	-761	3212	-0.192
Latvia	17298	-2787	14511	-0.161

V. IMPROVING OF PERMEABILITY MAPS FOR PRIMARY AQUIFERS

For the LAMO3 version, its k -maps were improved by using the data provided by the pumping tests of wells [5]. However, the following problems of using the formula (4) were not solved satisfactorily:

- jumpwise changes in k were not eliminated at locations of incised river valleys;
- in the $m \rightarrow 0$ areas, extreme values of k were not suppressed;
- data of well pumping tests were not validated.

For LAMO4, these drawbacks have been eliminated [7]:

- the jumpwise changes have been excluded, because the m_0 -maps without incisions were used for the LAMO4 case. Such maps are being used as the starting position for all necessary changes in the HM geometry;
- to suppress the extreme k values for the $m \rightarrow 0$ zone, the following correction matrix C was used:

$$1 > C = m_0 / (0.75 m_{\text{mean}}), \quad (7)$$

where the factor 0.75 was chosen empirically; m_{mean} is the mean thickness of an aquifer in its $m > 0$ area. The corrected k_{cor} and T for GV were obtained, as follows:

$$\gamma_{\text{cor}} = G \gamma, \quad k_{\text{cor}} = 137 \gamma_{\text{cor}}/m_0, \quad T = k_{\text{cor}} m, \quad (8)$$

where γ , liter/sec km², is the well's specific capacity which is obtained from a pumping test; m is the real m -map of LAMO4 where incisions of river valleys exist. The specific capacity γ data of (8) were taken only from verified wells. The verification was done by a special software tool that was developed for this task [6].

In Table X, the summary on the k -maps of LAMO2, LAMO3, and LAMO4 versions is given [6]. For each HM version, k_{mean} and $k_{\text{max}}/k_{\text{mean}}$ are presented. For the LAMO2 version, $k_{\text{max}}/k_{\text{mean}} = 1.0$, because constant values of k were used for all aquifers. For the LAMO3 and LAMO4 versions, the ratio $k_{\text{max}}/k_{\text{mean}}$ is variable. For LAMO4, the ratio $k_{\text{max}}/k_{\text{mean}}$ is larger than for the LAMO3 version, because the values $q_{\text{min}} = 0.2$ and 0.3 were used for bounding of the initial data of LAMO3 and LAMO4, correspondingly.

TABLE X

SUMMARY ON THE LAMO2, LAMO3 AND LAMO4 k -MAPS OF THE PRIMARY AQUIFERS

Aquifer code	LAMO2		LAMO3		LAMO4	
	k_{mean} , meter/day	$k_{\text{max}}/k_{\text{mean}}$	k_{mean} , meter/day	$k_{\text{max}}/k_{\text{mean}}$	k_{mean} , meter/day	$k_{\text{max}}/k_{\text{mean}}$
D3ktl#	3.0	1.0	2.12	9.0	1.77	12.10
D3zg#	3.0	1.0	3.64	5.33	3.38	15.75
D3krs#	2.0	1.0	5.95	4.35	6.33	9.89
D3dg#	10.0	1.0	5.58	14.38	9.40	16.06
D3pl	10.0	1.0	6.11	8.51	8.60	19.65
D3am	10.0	1.0	4.69	5.67	4.64	11.25
D3gi2	10.0	1.0	5.58	4.55	5.11	20.05
D3gi1	14.0	1.0	5.24	6.25	4.84	16.00
D2brt	5.0	1.0	1.91	5.83	3.19	13.75
D2ar	5.0	1.0	2.13	6.15	2.91	17.69

It is possible to improve the k -maps of LAMO4, if the data of screens positions of wells will be accounted for [6].

VI. APPLIANCE OF LAMO FOR GROUNDWATER PARTICLE TRACKING

In the GV system, the MODFLOW program [9] is used for running LAMO. This program is joined with the MODPATH program [10] that is applied for tracking of groundwater particles. MODTATH can provide useful results only if MODFLOW carries reliable HM, such as LAMO4. It is described in [11] that the appliance of MODPATH with the HM for Lithuania eastern part provided very impressive results on modeling isotope geochemistry.

MODPATH is often used for finding borders of sanitary protection zones of well fields. Then the migration time for water particles does not exceed 25 years.

In the paper [7], the case of the Iecava river is investigated by using MODPATH for finding sources of the river base flow. As expected, the inflow through the HM top surface (caused by precipitation) forms the river base flow. A small part of the base flow is caused by the ascending flow from the HM bottom surface. However, if the particle tracking time was not limited, it turned out that some amount of groundwater comes from the areas located very far from the drainage basin of the river. Also, it was not expected that even within the drainage basin, many particle traces had very complex 3D shapes. This unforeseen fact will be investigated for other rivers of the country.

VII. CONCLUSION

In 2015, the new upgrades of the hydrogeological model of Latvia LAMO4 were accomplished. The plane approximation step of the HM grid was decreased from 500 meters to 250 meters. The river flows of LAMO4 account for real measurements of the river streams of Latvia. The LAMO4 version will be applied for updating the information that is necessary for water management planning, as the base for building detailed local models, and for investigation of complex geochemical processes.

ACKNOWLEDGMENT

In 2010–2012, the hydrogeological model of Latvia LAMO1 was developed within the framework of the Riga Technical University project that was co-financed by the European Regional Development Fund. The current upgrades of LAMO3 and LAMO4 are supported by the Latvian State Research program EVIDEnT.

APPENDIX

ESTIMATION OF THE LATVIA'S MEAN RIVER BASE FLOW THAT SHOULD BE SIMULATED BY LAMO4

A. General Hydrological Relationships

For the steady state mean hydrological conditions of Latvia, the general relationship holds:

$$q_{\text{prec}} = q_{\text{inf}} + q_{\text{run}} + q_{\text{evap}}, \quad (1a)$$

where q_{prec} , q_{inf} , q_{run} , and q_{evap} are the mean flows of precipitation, infiltration, surface runoff, and evaporation, respectively.

The LAMO system simulates the spatial distribution of the infiltration q_{inf} that contains the following parts [4]:

$$q_{\text{inflow}} = q_{\text{rivers}} + q_{\text{lakes}} + q_{\text{wells}} + q_{\text{boundary}} \quad (2a)$$

where q_{rivers} , q_{lakes} , q_{wells} , and q_{boundary} are the mean flows of rivers (base flow), lakes, discharge wells, and the flow passing through the borderline of Latvia, accordingly.

The full flow of rivers q_{friv} , which can be directly measured, contains two parts:

$$q_{\text{friv}} = q_{\text{rivers}} + q_{\text{run}} \quad (3a)$$

The ratio:

$$q_{\text{rivers}} / q_{\text{friv}} = q_{\text{rivers}} / (q_{\text{rivers}} + q_{\text{run}}) \quad (4a)$$

displays the relative part of groundwater (base flow of a river) into the full flow q_{friv} . The measured flow q_{friv} in time is the river stream hydrograph.

To obtain q_{rivers} for a drainage basin, the hydrograph must be separated into its groundwater and surface runoff parts.

When the river base flow q_{rivers} is found, the groundwater inflow, thous.m³/day, into the river or its segment can be described by the relationship:

$$M_{\text{rivers}} = q_{\text{rivers}} / (86.4 L_{\text{rivers}}), \quad (5a)$$

where M_{rivers} (liter/sec km²) and L_{rivers} (thous. km²) are the river drainage module and the area of the drainage basin, respectively.

In books [12] and [13], the data of M_{rivers} are available for the river stream monitoring stations of Latvia. The isoline maps of M_{rivers} are also presented for the land area of the country.

It can be deduced from [12] that the general hydrological parameters of Latvia have the following mean values (mm/year): $q_{\text{prec}} = 710$; $q_{\text{inf}} = 80$; $q_{\text{run}} = 185$; $q_{\text{evap}} = 445$. For LAMO3, $q_{\text{rivers}} \sim 0.87 q_{\text{inf}}$. Therefore:

$$q_{\text{rivers}} \sim 70 \text{ mm/year} \sim 12 \text{ 4000 thous.m}^3/\text{day};$$

$$q_{\text{rivers}}/q_{\text{friv}} = 70 / (70+185) = 0.275;$$

$$M_{\text{rivers}} = 12 \text{ 400} / (86.4 \times 64.5) = 2.22 \text{ liter/sec km}^2.$$

The $q_{\text{rivers}} \sim 124 \text{ 000 thous.m}^3/\text{day}$ is the mean value for the land territory of Latvia. To calibrate LAMO by accounting for the results of measured river stream flows, the distributions of q_{rivers} and M_{rivers} have to be found for local drainage basins.

It is explained in [14] and [15] how from the hydrograph of a river, the base flow q_{rivers} can be sorted out. Estimates of q_{rivers} for LAMO4 were obtained by using the data of books [12] and [13].

B. Estimation of the River Base Flows for Local Drainage Basins

The land territory of Latvia was divided into 69 primary local drainage basins (Fig. 1a). Each basin is enveloped by its polygon. By using the polygon, in GV the full mass balance (2a) for the drainage basin and for its Quaternary aquifer Q2 can be obtained. The difference of these balances gives the balance for the primary aquifers. By using these data, calibration of q_{rivers} for the basin can be done by comparing the projected river flows as targets with the existing ones. The existing flows must be changed in order to match the targets. In most of the cases, the result can be achieved by adjusting the links of rivers with the drainage basin.

Each primary drainage basin is marked by its number that contains four positions. The positions have the following meaning:

- the first is the number of the four united river basins of Latvia: 1 – Gauja; 2 – Daugava; 3 – Lielupe; 4 – Venta;
- the second is the number of subbasins of the united ones; the basins have the following number of subbasins: Gauja – 3; Daugava – 2; Lielupe – none; Venta – 4;
- the third denotes the numbers of segments of subbasins of the four larger rivers which have the following number of segments: Gauja – 7; Daugava, Lielupe, Venta – 4. The number of segments and their location depends on the set of river stream monitoring posts on a river;
- the fourth is the number of the primary drainage basin within a segment.

In Fig. 1a, Fig. 2a, Fig. 3a, and Fig. 4a, accordingly, the 69 primary drainage basins, 34 segments of basins, 10 subbasins, and 4 united basins are shown.

To estimate the river base flow for the primary drainage basins, the map of isolines for the drainage module M [12] was projected on the map of Fig. 1a (see Fig. 5a). By taking into account the data carried by Fig. 5a and the information provided by the book [13], the river base flows for each of the 69 primary drainage basins were estimated (Table IA). By using data of Table IA, the estimated river base flows for 4 united basins and 10 subbasins were obtained (Table IIA). Table IIIA contains data for segments of the four largest rivers of Latvia.

The mean estimated river base flow 12 423 thous. m³/day for Latvia (Table IIA) is only slightly larger than 12 400 thous. m³/day that was obtained from the general hydrological parameters of Latvia.

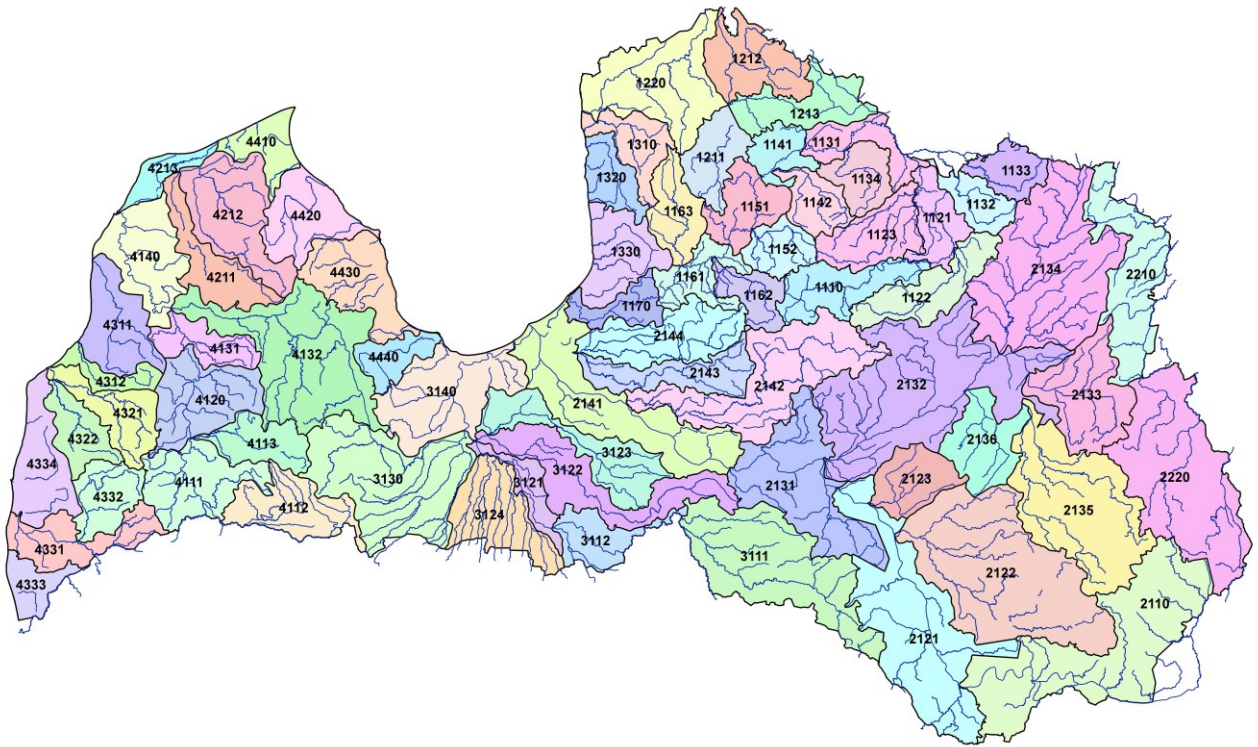

Fig. 1a. 69 primary drainage basins used for calibration of river flows.



Fig. 2a. 34 segments of monitored river basins.



Fig. 3a. Ten river subbasins of Latvia.



Fig. 4a. Four united river basins of Latvia.

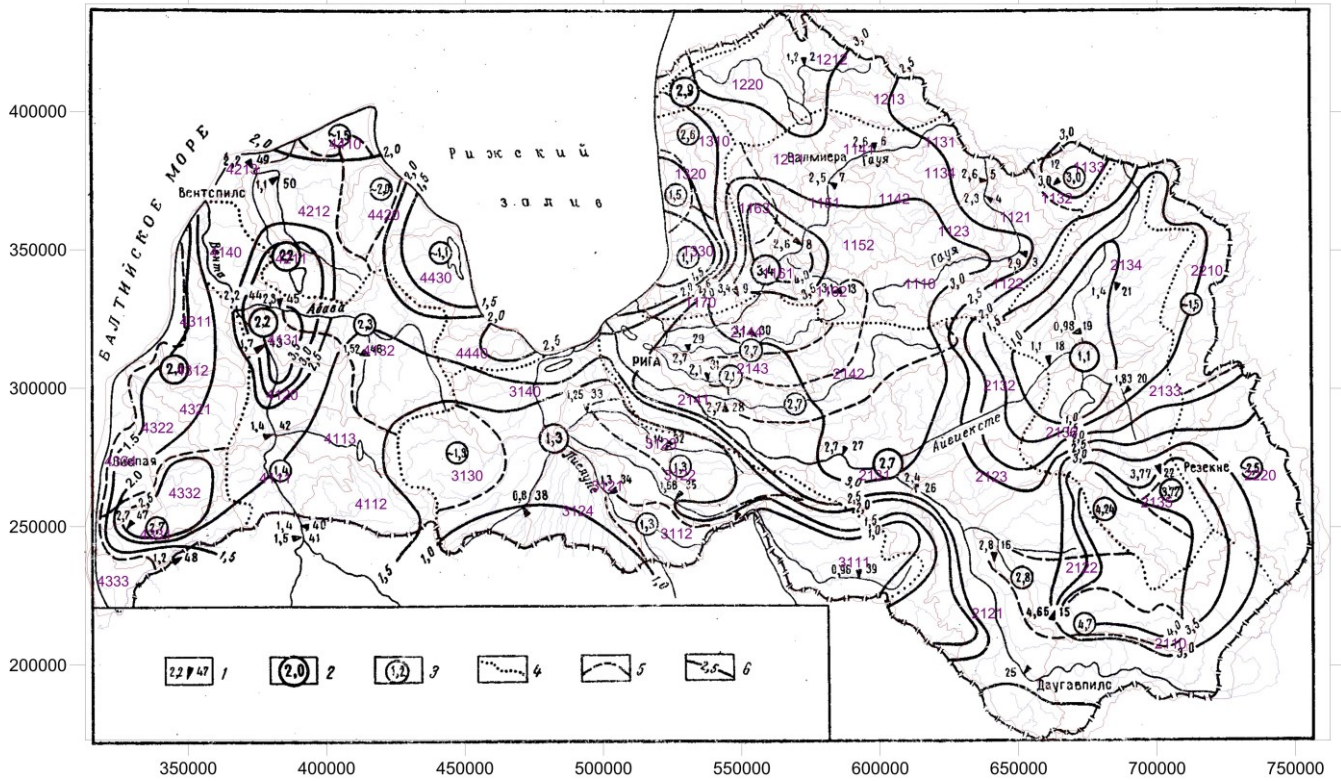

Fig. 5a. The map of drainage modules [12] projected on the map of primary basins.

TABLE IA
ESTIMATED RIVER BASE FLOWS FOR PRIMARY BASINS

No.	Name of the basin	Primary basin index	Area, km ²	Drainage module, liter/sec km ²	Flow, thous.m ³ /day		
					Target	Simulated	Residual
1	Gauja source-Velēna	1110	719.2	2.70	168	166	-2
2	Gauja Velēna-Gaujiena	1121	481.3	2.80	116	118	2
3	Tirza	1122	751.3	2.40	156	155	-1
4	Vizla, Palsa	1123	696.9	2.50	150	152	2
5	Gauja Gaujiena-Strenči	1131	470.2	3.30	134	135	1
6	Melnupe	1132	381.5	2.80	92	92	0
7	Vaidava	1133	400.6	3.20	111	113	2
8	Vija	1134	456.8	2.50	98	96	-2
9	Gauja Strenči-Valmiera	1141	359.2	1.90	59	58	-1
10	Abuls	1142	427.0	3.20	118	115	-3
11	Gauja Valmiera-Cēsis	1151	584.2	4.00	202	204	2
12	Rauna	1152	409.0	3.30	117	116	-1
13	Gauja Cēsis-Sigulda	1161	480.5	9.30	386	380	-6
14	Amata	1162	388.7	5.70	191	190	-1
15	Brasla	1163	552.1	3.60	172	168	-4
16	Gauja Sigulda-sea	1170	370.1	5.40	172	173	1
17	Briede	1211	542.1	3.00	140	143	3
18	Rūja	1212	799.7	1.40	97	93	-4
19	Seda	1213	703.0	2.60	158	158	0
20	Salaca	1220	1368.9	3.50	414	415	-1
21	Svētupe	1310	505.9	1.90	83	82	-1
22	Vītrupe, Liepupe	1320	422.1	2.10	76	76	0
23	Aģe and other small rivers	1330	733.7	1.10	70	71	1
24	Daugava border-Daugavpils	2110	2459.9	2.60	552	549	-3
25	Daugava Daugavpils-Jēkabpils	2121	2210.0	2.70	516	523	7
26	Dubna	2122	2753.4	2.50	595	589	-6

27	Nereta	2123	572.8	1.70	84	86	2
28	Daugava Jēkabpils-Pļaviņu HES	2131	1517.1	2.30	301	301	0
29	Aiviekste	2132	2946.3	2.30	585	582	-3
30	Iča	2133	1039.9	1.40	126	127	1
31	Pededze, Balupe	2134	2457.5	1.90	403	407	4
32	Rēzekne, Malta	2135	1968.3	2.50	425	416	-9
33	Meirānu canal	2136	706.1	1.20	73	73	0
34	Daugava Pļaviņu HES-sea	2141	1693.8	1.60	234	234	0
35	Ogre	2142	1681.4	2.50	363	360	-3
36	Mazā Jugla	2143	705.6	2.30	140	138	-2
37	Lielā Jugla	2144	943.9	3.10	253	249	-4
38	Veļikaja basin northern part	2210	1200.3	1.50	155	149	-6
39	Veļikaja basin southern part	2220	2207.3	2.00	381	331	10
40	Mēmele border-Viesīte	3111	1896.8	1.20	196	203	7
41	Mēmele Viesīte-Bauska	3112	489.5	2.70	114	113	-1
42	Lielupe Bauska-Iecava	3121	319.6	2.20	60	61	1
43	Iecava	3122	1174.2	1.50	152	147	-5
44	Misa	3123	907.3	1.50	117	116	-1
45	Rivers from Lithuanis	3124	889.6	1.20	92	94	2
46	Lielupe, Svēte Iecava and Svēte months	3130	1890.7	1.30	212	209	-3
47	Lielupe Svētes mouth sea	3140	1289.5	1.50	167	170	3
48	Venta border-Skrunda	4111	917.4	2.80	222	222	0
49	Vadakste	4112	785.6	1.80	122	122	0
50	Ciecere	4113	534.7	1.70	78	79	1
51	Venta Skrunda-Kuldīga	4120	942.6	2.60	211	208	-3
52	Venta Kuldīga-Abava mouth	4131	461.1	2.80	111	111	0
53	Abava	4132	2058.2	2.10	373	379	6
54	Venta Abava mouth-sea	4140	925.5	2.00	160	157	-3
55	Rinda	4211	672.2	1.70	99	100	1
56	Stende	4212	1148.8	2.00	198	195	-3
57	Irbe	4213	270.8	2.10	49	51	2
58	Užava	4311	776.1	1.50	100	99	-1
59	Rīva	4312	265.2	1.40	32	30	-2
60	Saka	4321	617.9	1.90	101	100	-1
61	Durbe	4322	479.0	1.70	70	69	-1
62	Bārta	4331	700.9	2.80	169	170	1
63	Vartaja	4332	535.8	2.70	125	123	-2
64	Sventaja	4333	327.0	1.40	39	38	-1
65	Liepāja lake small rivers	4334	778.9	1.00	67	65	-2
66	Pilsupe	4410	417.5	1.40	50	50	0
67	Roja, Grīva	4420	773.5	1.20	80	80	0
68	Engure lake rivers	4430	870.1	1.40	105	106	1
69	Slocene	4440	371.1	2.50	80	80	0
70	Latvia	0	64 554.7	2.22	12 423	12 388	-35

TABLE IIA
ESTIMATED RIVER BASE FLOWS FOR LAMO

Name of the basin	Area, km ²	River flow, thous.m ³ /day	Drainage module, liter/sec km ²	Basin index
Gauja united basin	13 004.0	3469	3.09	1000
Daugava united basin	27 063.6	5172	2.21	2000
Lielupe united basin	8857.2	1113	1.45	3000
Venta united basin	15 629.9	2634	1.95	4000
Latva in total	64 554.7	12 388	2.22	0
Base flows for subbasins of the Gauja united basin 1000				
Gauja basin	7928.6	2431	3.50	1100
Salaca basin	3413.7	809	2.74	1200
Basin of small rivers of Vidzeme coast	1661.7	229	1.59	1300
In total	13 004.0	3469	3.09	1000

Base flows for subbasins of the Daugava united basin 2000				
Daugava basin	23 656.0	4628	2.20	2100
Veļikaja basin	3407.6	544	1.85	2200
In total	27 063.6	5172	2.21	2000
Base flows for subbasins of the Venta united basin 4000				
Venta basin	6625.1	1278	2.23	4100
Irbe basin	2091.8	346	1.91	4200
Basin of small rivers for western Kurzeme coast	4480.8	694	1.79	4300
Basin of small rivers for eastern Kurzeme coast	2432.2	316	1.50	4400
In total	15 629.9	2634	1.95	4000

TABLE IIIA
BASE FLOWS FOR SEGMENTS OF THE GAUJA RIVER 1100

No.	Index of segment	Area, km ²		River flow, thous.m ³ /day		Drainage module, liter/sec km ²	
		Segment	River	Segment	River	Segment	River
1	1110	719.2	719.2	160	160	2.67	2.67
2	1120	1929.5	2648.7	425	591	2.55	2.59
3	1130	1709.1	4357.8	436	1027	2.97	2.72
4	1140	786.2	5144.0	173	1200	2.57	2.70
5	1150	993.2	6137.2	320	1520	3.74	2.88
6	1160	1421.3	7558.5	738	2258	6.01	3.46
7	1170	370.1	7928.6	173	2431	5.41	3.55
In total	1100		7928.6		2431		3.55

BASE FLOWS FOR SEGMENTS OF THE DAUGAVA RIVER 2100

No.	Index of segment	Area, km ²		River flow, thous.m ³ /day		Drainage module, liter/sec km ²	
		Segment	River	Segment	River	Segment	River
1	2110	2459.9	2459.9	549	549	2.58	2.58
2	2120	5536.2	7936.1	1192	1741	2.50	2.55
3	2130	10635.2	18 631.3	1906	3647	2.09	2.28
4	2140	5024.7	23 656.0	981	4628	2.27	2.26
In total	2100		23 656.0		4628		2.26

BASE FLOWS FOR SEGMENTS OF THE LIELUPE RIVER 3100

No.	Index of segment	Area, km ²		River flow, thous.m ³ /day		Drainage module, liter/sec km ²	
		Segment	River	Segment	River	Segment	River
1	3110	2386.3	2386.3	316	316	1.53	1.53
2	3120	3290.7	5677.0	418	734	1.47	1.50
3	3130	1890.7	7567.7	209	943	1.28	1.44
4	3140	1289.5	8857.2	170	1113	1.32	1.45
In total	3100		8857.2		1113		1.45

BASE FLOWS FOR SEGMENTS OF THE VENTA RIVER 4100

No.	Index of segment	Area km ²		River flow, thous.m ³ /day		Drainage module, liter/sec km ²	
		Segment	River	Segment	River	Segment	River
1	4110	2237.7	2237.7	423	423	2.19	2.19
2	4120	942.6	3180.3	208	631	2.55	2.30
3	4130	2519.3	5699.6	490	1121	2.25	2.28
4	4140	925.5	6625.1	157	1278	1.96	2.23
In total	4100		6625.1		1278		2.23

REFERENCES

- [1] Water Framework Directive. 2000. (2000/60/EC of the European Parliament and of the Council). *Official Journal of the European Communities*, L327, 22.12.2000.
- [2] Environmental Simulations, Inc., Groundwater Vistas. Version 6, Guide to using, 2011.
- [3] A. Spalvins, J. Slangens, I. Lace, K. Krauklis, and O. Aleksans, "Efficient Methods Used to Create Hydrogeological Model of Latvia," In *International Review on Modelling and Simulations (I.R.E.MO.S)*, Praise Worthy Prize, vol. 6, no. 5, Okt. 2013, pp. 1718–1726.
- [4] A. Spalvins, J. Slangens, I. Lace, O. Aleksans, K. Krauklis, "Improvement of hydrogeological models: a case study," *International Review on Modelling and Simulations (I.R.E.MO.S)*, Praise Worthy Prize, Naples, Italy, vol. 8, no. 2, April 2015, pp. 266–276
- [5] A. Spalvins, O. Aleksans, I. Lace, "Improving of transmissivity maps for hydrogeological model of Latvia," in *15th international multidisciplinary scientific geo conference (SGEM 2015), June 18–24, 2015*, Albena, Bulgaria, Conference Proceedings, 2015, vol. 1, pp. 667–684
- [6] A. Spalvins, I. Lace, K. Krauklis, "Improved methods for obtaining permeability maps of aquifers for hydrogeological model of Latvia," *Scientific Journal of Riga Technical University, Boundary Field Problems and Computer Simulation*, RTU Press, Riga, 2015.
- [7] K. Krauklis, A. Spalvins, J. Slangens, "Hydrogeological model of Latvia LAMO4 as a tool for investigating processes of nature. Sources of groundwater inflow for Iecava river," *Scientific Journal of Riga Technical University, Boundary Field Problems and Computer Simulation*, RTU Press, Riga, 2015.
- [8] G. Strang, *Linear algebra and its applications*. Academic Press Inc., New York, 1976, p. 373.
- [9] A.W. Harbaugh, *MODFLOW-2005, U.S. Geological Survey Modular Ground-Water Model: the ground-water flow process*, chap 16, book 6, US Geological Survey Techniques and Methods 6-A16, USGS, Reston, VA
- [10] Pollok D. W. User's Guide for MODPATH/MODPATH-Plot, Version3. A particle tracking post-processing package for MODFLOW, the US Geological Survey finite-difference groundwater flow model, U.S. Geological survey, September 1994.
- [11] R. Mokrik, V. Juodkazis, A. Stuopis, and J. Mazeika, "Isotope geochemistry and modelling of the multi-aquifer system in the eastern part of Lithuania," *Hydrogeology journal*, vol. 22, 2014, pp. 925–941.
- [12] Dzenis-Litovsky A. I., editor, *Hydrogeology of USSR, Latvian SSR*, Volume XXXI, part1, Nedra, Moskow 1967, p. 200 (in Russian).
- [13] I. Dzilna., *Resources, composition and dynamics of groundwater for the middle part of the Baltic area*. (Zinatne, Riga, 1970, p. 197, (in Russian).
- [14] P. A. Domenico, and F.W. Schwartz. *Physical and Chemical Hydrogeology*, John Wiley and sons, Inc. – 2 end ed. New York, p. 506, 1998.
- [15] De Barry, Paul A., *Watersheds: processes assessment and management*. Willey and Sons Inc. Hoboken, New Jersey, 2004, p. 700.

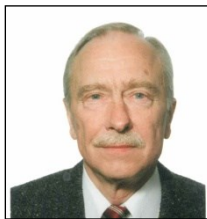

Janis Slangens was born in Latvia. In 1969, he graduated from the Riga Polytechnical Institute (since 1990 – Riga Technical University) as a Computer Engineer. J. Slangens is a senior researcher at the Environment Modelling Centre of RTU. His research interests include computer modeling of groundwater flows.

E-mail: janis.slangens@rtu.lv

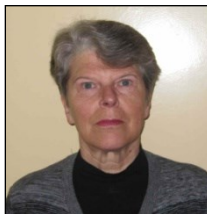

Inta Lace was born in Latvia. In 1971, she graduated from the Riga Polytechnical Institute (since 1990 – Riga Technical University) as a Computer Engineer. In 1995, I. Lace received the Master's degree in Applied Computer Science. Since 1991, she is a researcher at the Environment Modelling Centre of the Faculty of Computer Science and Information Technology, RTU.

E-mail: inta.lace@yahoo.com



Olgerts Aleksans was born in Latvia. In 1979, he graduated from Vilnius State University as a Hydrogeologist & Engineering Geologist. In 2011, O. Aleksans received the Doctor's degree in Geology. Since 2011, he is a researcher at the Environment Modelling Centre of RTU.

E-mail: oal@dge.lv



Kaspars Krauklis received the Master's degree in Computer Systems from the Riga Technical University in 2007 and the Certificate in Teaching of Engineering Sciences from the Institute of Humanities of RTU in 2005. He is a researcher at the Environment Modelling Centre of RTU.

E-mail: Kaspars.Krauklis@gmail.com

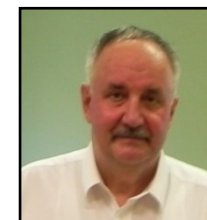

Viesturs Skibelis was born in Germany in 1945. In 1967, he graduated from the Riga Polytechnical Institute (since 1990 – Riga Technical University) as a Computer Engineer. In 2001, he received the Master's degree in Applied Computer Science. He is a researcher at the Environment Modelling Centre of RTU.

E-mail: Viesturs.Skibelis@cs.rtu.lv



Irina Eglite received the Master's degree in Mathematics from the University of Latvia and the Master's degree in Applied Computer Science from the Riga Technical University. She is a PhD student at RTU, a researcher at the Environment Modelling Centre and a lecturer at the Department of Engineering Mathematics, RTU.

E-mail: Irina.Eglite@rtu.lv



Aivars Spalvins was born in Latvia. In 1963, he graduated from the Riga Polytechnical Institute (since 1990 – Riga Technical University) as a Computer Engineer. A. Spalvins is the Head of the Environment Modelling Centre of RTU. His research interests include computer modeling of groundwater flows and migration of contaminants.

E-mail: aivars.spalvins@rtu.lv